

Fall 2017 ECE 486 Senior Design Projects

ECE 486 Project 1: Intelligent Ground Vehicle

Faculty Advisor: Dr. Lee Belfore

Student Group Members: Gordon Rarick, Tony Edwards, Justin Santos, Richard Kazmer, Adam Seay

The purpose of this project is to design and build an Intelligent Ground Vehicle (IGV) that will compete in the Annual Intelligent Ground Vehicle Competition in Michigan. This vehicle will be an autonomous robotic vehicle designed within the constraints of the competition guidelines. This project improves and provides modifications to previous teams' design and implementation. The vehicle uses a wheelchair chassis as its base. Sensors on the robot provide capabilities such as line tracking, obstacle detection and avoidance, and waypoint navigation. Software implementation tools, like Robot Operation System (ROS), Arduino Integrated Development Environment (IDE) and Open Source Computer Vision (OpenCV), allow the vehicle's hardware to work in unison. Building on the vehicle's current capabilities, night vision will be added.



Currently, the ECE 487 team has a working vehicle, with hardware consisting of the Pride Wheelchairs modular base with motors, the hardware enclosure, the battery system, two working Emergency Stops (wireless and on-board push-button), individual motor drives for right and left wheels, a motherboard with an AMD CPU, two Arduino UNO microcontrollers for controlling the motor drives, a LiDAR system, an Inertial Measurement Unit (IMU), a GPS receiver, and several camera choices under development. In terms of software and control, the operating system is LINUX for the main computer. The microcontrollers run the Arduino IDE. Robot Operating System (ROS) operates on the LINUX shell and ties everything together making the pathing decisions. Line detection is operational and is implemented using OpenCV, but GPS and LiDAR have not yet been integrated. Extensive use of the USB interface has recently been employed by the ECE 487 team, which will aid in the future development of the guidance and navigation systems over the previous design.

This group plans to accomplish its objectives by first researching the available options for the night vision and GPS tracking technologies. These components will serve an important role in the autonomous operation of the IGV, so it is imperative that these components meet all requirements for this application. After these selections are finalized, the new boards for the IGV as well as the GPS tracking are to be operational. With all this complete, the IGV's movement capabilities are to be tested along with its targeting and obstacle avoidance capabilities.

The proposed physical changes to the robot are to streamline the enclosure for increased interior space and provide more reliable interfacing between components. Additionally, the night vision system will consist of a night vision camera that will be selected later in the semester and will enable the system to operate in low light conditions. Finally, the team will transfer the previous teams' developed code to a pair of identical desktop motherboards each with identical AMD processors. These computers will be running Ubuntu 16.04 with ROS installed so that the team can have a dedicated PC for further development in the lab, and another board that remains installed on the IGV. Over the course of the next two semesters, the team will also be developing the decision-making algorithms that will allow the IGV to autonomously navigate the competition course using all its sensor inputs.

ECE 486 Project 2: Vision Guided Mobile Robot for Automated Surveillance in Noisy and Unstable Environment

Faculty Advisor: Dr. Khan M. Iftekharuddin

Student Group Members: Corey Auguillard, Matthew Nilsen, Leon Gregg, Tylin Scott



Figure 1: Wireless control panel for MARCbot robot (left) and MARCbot robot (right)

The goal of this project is to resume the construction of an automated surveillance robot built by a previous team which currently entails facial recognition, remote access/control, and video data processing. The current model is handicapped in the realm of tracking the face/figure found once the face/figure is out of the field of view. Our task in this project is to improve, expand, and deliver a solution to the tracking problem the previous team experienced. The final product should be able to travel via remote and select a face/figure to track; this device will also be expected to be versatile and perform these task in adverse weather conditions such as wind, rain, sunshine, or moonlight. The bridge of hardware and software components involved in this project call for a team of students proficient in electric circuits and programming.

The current problem we face when looking into improvements of the robot is the current direction the robot's hardware is headed. The original solution for facial recognition and tracking was to acquire and implement a lidar sensor. Lidar sensing is the method of detection by using light and ranging technology to determine the qualities of a surface. Lidar sensors with capabilities needed to fulfill this project are also extremely expensive ranging from \$3000 – \$5000. As a group we concluded that using the lidar technology for sensing would aid in the facial recognition aspect of things but not so much when it is time to track the face or when noisy conditions arise such as a bright day outside. To combat this problem we developed a solution similar to the original but will in fact provide more benefits if implementation goes as planned.

As a group we decided to look into using radar sensing technology as a substitution for the lidar sensor.

Radars use a different method to sense and examine the qualities of surfaces of nearby objects. By using radar, we are able to eliminate the stress of noisy conditions by changing the frequencies to avoid picking up the motion of unwanted things like rain, debris, or wind; the robot also benefits with radar by completely eliminating the concerns regarding extreme or changing lighting conditions. Radars are notoriously known for their use in the tracking of objects large and small and many can be found inexpensively. These qualities together make radar a better candidate for this project when compared to the usage of lidar.

If the budget allows for the team to complete the major part of the project with funds remaining, we would like to improve a few things on the current robot. Most importantly improving the camera onboard to a better camera with a higher resolution equipped with a wide angle lens or multiple cameras with a stitched product

forming a panoramic photo. This will aid in the initial capture of the face/figure giving the radar better dimensions and data to scan for and keep track of. Also altering the aesthetics of the robot was discussed amongst the group. Increasing the height of the robot by increasing the wheel gap should allow for a tighter turn radius and result in more maneuverability thus allowing the robot to follow the face/figure keeping it in range and decreasing the time allowed for the face/figure to escape the robot's field of view. The removal or modification of the arm was another aesthetic change discussed amongst the group; aiming to replace the current system with a more robust system that can either rotate on a pivot to allow a minimum of 180 degree scanning of the surroundings or be built on a platform with 2-3 independently mounted cameras feeding data to the computer which will stitch and analyze the photos. Both changes will increase visibility and decrease the chance of losing the face/figure.

To achieve these goals, we will be researching the use and implementation of radar technology and also developing code in Labview/Matlab that will communicate with the computer onboard. This code should be able to receive and process image data from the onboard cameras then relay the data to the radar, giving it instructions for an object to scan and track.

ECE 486 Project 3: Autonomous HHO Generator for Internal Combustion Engine

Faculty Advisor: Dr. W. Steven Gray

Student Group Members: Bryson Goforth, Petey Hazy, Shane Wright, Robert French, Asa Holm

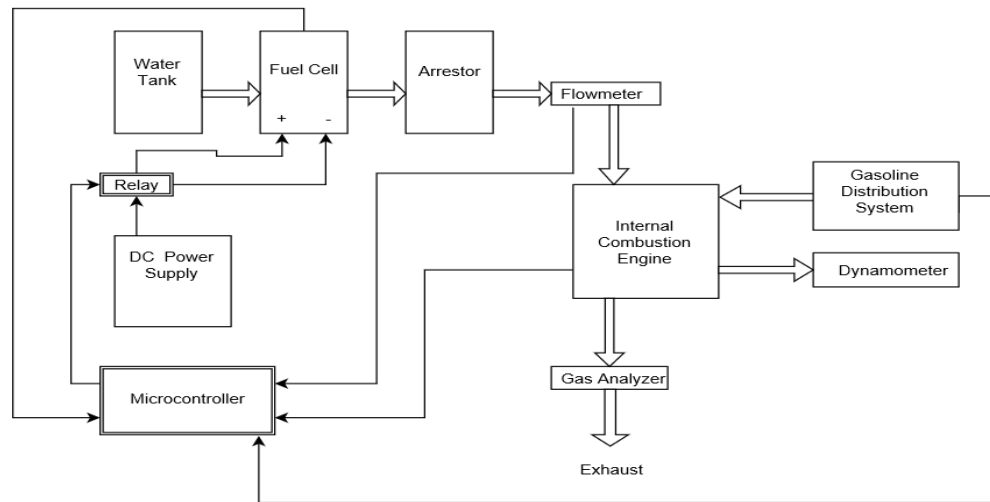

Figure 1: Block Diagram

The primary goal of this project is to improve the efficiency of an internal combustion engine (ICE) utilizing an automatic control system to deliver oxyhydrogen gas (HHO) to the gasoline fuel. Specifically, the control system will sense RPM and generate the corresponding optimum amount of HHO gas flow to improve the efficiency of combustion. A secondary goal is to reduce carbon emissions since when HHO combusts, the exhaust produced is water vapor. The emissions will be analyzed to determine if adding HHO to a combustion engine generates less carbon emissions.

The proposed system will consist of three subsystems: a programmable logic controller (PLC) to monitor the system, an HHO cell to generate the gas, and a four-stroke ICE. Figure 1 below gives a block diagram. The principle of the operation is as follows. The HHO cell will be filled with distilled water and potassium hydroxide electrolyte. The DC power source will apply voltage and current to electrode plates within the cell causing the water to split into H_2 and O_2 . This HHO will be filtered into the ICE at the carburetor after the throttle valve.

Design constraints that have been encountered for this project have been power availability, engine modifications, safety, and timing difficulty. As the ratio of HHO to gasoline increases, so does the demand for power in the system. A DC power supply would create ideal consistent results, but does not fit into the budget. So the team will improvise with 12V car batteries. The engine will be a commercial model modified by the team. In an ideal experiment, the team would create a custom engine to fit the parameters. Utilizing a combustion engine also demands safety precautions. The control system will monitor temperature and pressure throughout, but the engine will need mechanical modifications to ensure safety of the team and the equipment. In a system of three separate subsystems, timing becomes an issue as well. Each system will have its own time constant, so the team must account for delays to sync the subsystems together.

The system will be tested to find an optimal flow of HHO gas. Gasoline will still be used in the ICE as a primary fuel source. After trial tests to make sure each subsystem is working, the team will inject HHO at varied RPMs and find the optimal flow rate of HHO gas for each speed. This data will be used to model the system efficiency at a specified RPM as a function of HHO flow. The output of the HHO cell will be controlled by a pulse width modulator (PWM). This pulse width modulator will sense engine RPM and adjust the duty cycle to appropriately produce the required flow of HHO. The flow output of the HHO cell will be measured by a pressure sensor within the cell. This pressure sensor will read the internal pressure in PSIG and relate that value to an exact flow rate in liters per minute (LPM) for each percent of duty cycle increase and decrease.

ECE 486 Project 4: Development of Ultracapacitor for Energy Sources

Faculty Advisor: Dr. Gon Namkoong

Student Group Members: Kaylee Arceo, Jeremy Hancock, Shawn Harrison

The purpose of this project is to design an ultracapacitor that includes a thin film ceramic around the electrode to increase the capacitance. This device will allow for a capacitance density that is 100 to 200 times greater than a standard parallel plate capacitor around $1\text{F}/\text{cm}^3$.

$$(1) \quad C = \epsilon \frac{A}{d}$$

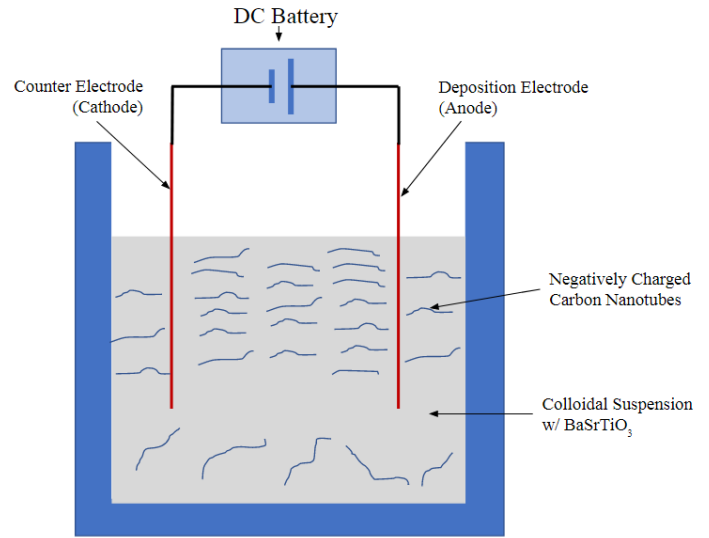

Figure 1: Schematic Diagram of EPD of Carbon Nanotubes

Equation 1 is the formula for parallel plate capacitance, C . Using carbon nanotubes on the electrode increases the surface area of the electrode, therefore, increasing the capacitance due to their porous nature which increases the area, A . Where the permittivity, $\epsilon = \epsilon_0 \epsilon_r$, is the product of the permittivity of free space (constant), ϵ_0 , and the dielectric constant of the insulator, ϵ_r . Using different insulators will determine the dielectric constant of the insulator and determine the permittivity. The BaSrTiO₃ is typically 7,000 to 15,000 at room temperature (25°). The idea for this project is to add a very thin layer of BaSrTiO₃, due to its high dielectric constant, as an interface between the electrode and the electrolyte. The thin ceramic film will only be nanometers thick, not drastically changing the distance between the positive and negative concentration of charges between the electrolyte and electrode, d , in equation 1.

The electrodes used in this experiment will be carbon nanotubes (CNT) backed with a metallic electrode, stainless-steel. Then a thin film ceramic coating will be BaSrTiO₃. To deposit the BaSrTiO₃ onto the CNT, using electrophoretic deposition. The BaSrTiO₃ will be mixed with distilled water to form a colloidal suspension in which to immerse the stainless-steel backed carbon nanotubes. A DC battery will be connected into the solution via anode and cathode wires. The negatively charged electrode will stabilize as it becomes attracted to the anode and the complementary positively-charged BaSrTiO₃ will deposit onto the exposed side of the carbon nanotubes in a thin nanometers thick film. For BaSrTiO₃, increase particle penetration and coverage is achieved by using a lower electric field intensity (E) at longer exposure times. At an electric field intensity of 5 V/cm for 80 minutes will yield 83% coverage.

After the BaSrTiO₃ has completed its deposition phase, the two plates are then placed around a porous material known as the separator which segregates the charges on each side of the ultracapacitor. The joined side and separator are then soaked in the electrolyte propylene carbonate before being placed into its enclosure. Propylene carbonate is advantageous due to its high dielectric constant and good compatibility with carbon electrodes enabling the dissolution of salts to sufficient concentrations.

ECE 486 Project 5: Thermal Vaporization Source

Faculty Advisor: Dr. Hani Elsayed-Ali

Student Group Members: Bryan Brooks, Benjamin Lehman, Daniel Parchuk, Amanuel Tesfamichael, William Hoggard

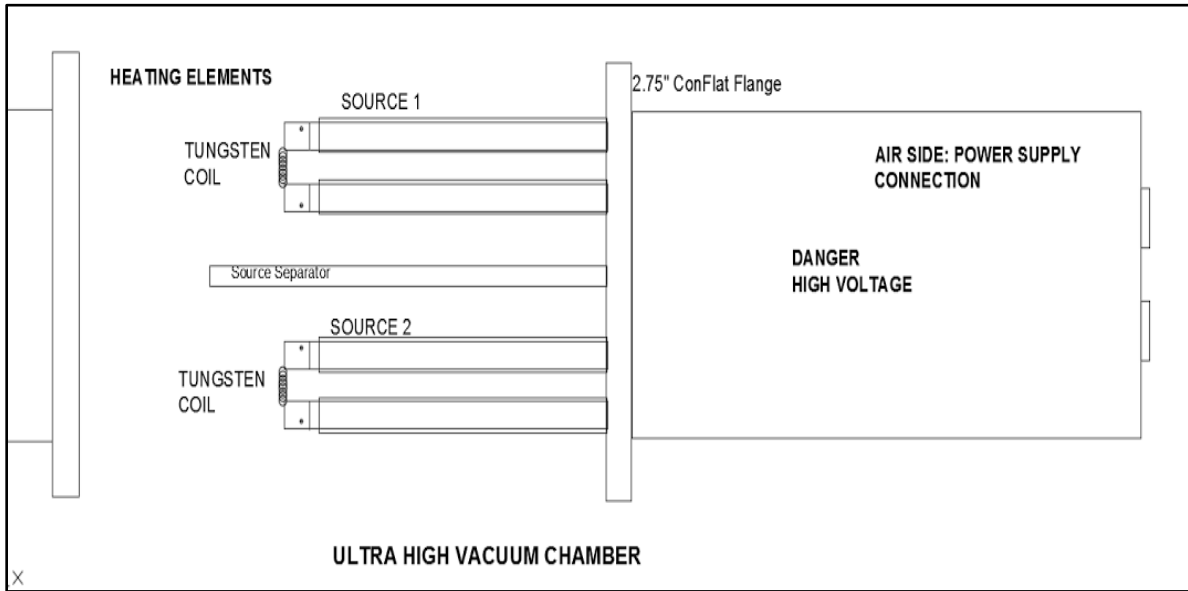

Dual Element Thermal Evaporator Source

Thermal Evaporators are used in thin film Nano-material deposition to evaporate material for deposition on substrate surface. These systems utilize Ultra High Vacuum (between 10^{-12} and 10^{-9} Torr) chambers, also referred to as UHV chambers. A high current power supply applies a current (upwards of 300A depending on the method of evaporation) to the heating element that allows the material to be deposited to be heated to the point of evaporation. The constructed thermal source will be able to heat material to approximately 1000° C. The evaporated material is then condensed on a substrate target inside the chamber.

This project will construct a dual element thermal evaporator with mechanical shutters to allow deposition of two different material onto a substrate without having to break the vacuum to change the source. A physical separation barrier will be constructed to prevent cross contamination of the source materials. This project will allow research into nanomaterial fabrication for future research.

The evaporated source will consist of a dual element tungsten heating source upon which the material to be evaporated will be wound. A dual variable high current power supply will be used to supply electrical power to the heating element. A dual shutter arrangement will allow the external control of which material is deposited.

LabVIEW will provide a control mechanism to allow programmed control of the power supply and shutter system. The thermal evaporation unit will be connected to the UHV chamber via a standard 2.75" CF(ConFlat) flange. Due to the ultra-high vacuum environment the materials on construction for the source will be constrained to refractory metals or materials with low vapor pressure. This will prevent undesired material from being deposited on the substrate surface.

Once constructed, the team will proceed to create various metal-based nanomaterials for research. Ultimately the thermal evaporation process will be utilized in conjunction with laser deposition system to maximize the benefits of both systems. These test pieces will be analyzed using an electron microscope.

ECE 486 Project 6: Smart Watch

Faculty Advisor: Chunsheng Xin, Lee Belfore

Student Group Members: Kaypee Paragas, Nathaniel Chandler, Son Nguyen, Dawit Teshome, Addie Wright, Adam Moore, Meghan Melton

The purpose of this project is to create a smartwatch geared towards health monitoring. With the recent popularity in products such as the Fitbit and the Apple Watch, we continue to see a trend of traditional everyday activities converging towards a mobile lifestyle. Based on last year's group, they were able to recreate some key features found in these commercial products and implemented them into a working prototype. These features included a heart rate monitor, a body temperature reader, and a step counter. This year, we plan to improve on those existing features, as well as implement additional ones. Our main vision is to move beyond the prototype and create a final product using the PCB (Printed Circuit Board) as our foundation for the smartwatch. This project requires the collective effort of both electrical engineering students and computer engineering students in order to construct a quality product.

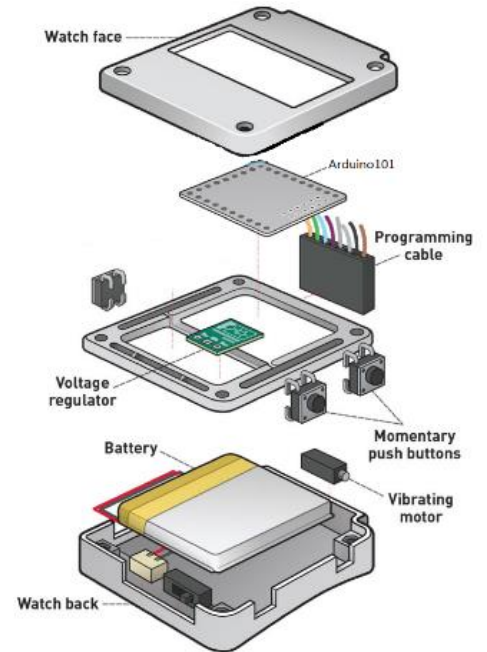

Figure 2: 2016-17 SmartWatch Prototype

For last year's hardware implementation, they've included the Arduino 101, DS18B20 Temperature Sensor, and a pulse sensor. Last year's prototype is shown in Figure 1. One of the main adjustments we are focused on is to search for a more practical temperature sensor. Although it was capable in fulfilling its intended task, it was difficult to work around such an over-sized sensor. Another key component we are searching for is a microcontroller processor to be implemented onto our PCB board. The Arduino 101's microcontroller, the Intel Curie, is surface-mounted on its board, and it was able to perform all of the featured tasks stated earlier. The Intel Curie also had a built-in gyrometer, which eliminated the need for an external sensor to operate as a step counter. Our goal is to find a microprocessor that can substitute, if not exceed, the functionalities of the Arduino 101's microprocessor and is able to be mounted onto our PCB board.

Our group is split into three teams to accommodate for our engineering fields. These teams include hardware design, software design, and PCB design. The hardware team will mainly deal with the sensors needed on the smartwatch, so that they can understand their functionalities and implement them to the PCB board. The software team is responsible for creating two programs: one for the phone application and the other for the smartwatch. Lastly, the PCB team is accountable for constructing the design of the PCB and will take into consideration all of the hardware components needed for the smartwatch. Despite the explicit titles for each member, we are all dedicated to share the responsibilities if the circumstances required us to do so.

ECE 486 Project 7: VEX U Robotic Competition

Faculty Advisor: Dr. Gene Hou

Student Group Members: Douglas Cree, Zachary Poe, Armon Taylor

Three students from ECE Senior Design will be working in cross-discipline collaboration with six students from MAE Senior Design to return Old Dominion University to the Vex U Robotics field of competition. Each year the VEX Robotics organization issues a challenge to university student teams to design and build a robot that can interact, both autonomously and while under human control, with objects on a playing field. Each of the two competing teams receives points for its robot successfully achieving specific results. At the end of a two minute round the team whose robot has scored the most points wins the match. Previous ODU Teams have left behind an impressive legacy; in 2016 they claimed a Programming Skills Winner Award, and in 2017 received both a Judges Award and a Design Award while going all the way to the Worlds competition. This year's team is optimistic of successfully carrying on this proud tradition.



The specific game for the 2017-2018 year is called “In the Zone.” Game rules reward teams with points for using their robot to move cones weighing just less than 4 pounds to designated areas on the 12 feet by 12 feet square playing field. Additional points are awarded for stacking smaller quarter-pound cones on top of these heavier cones. The robot has 45 seconds to do this on its own followed by 75 seconds of human control. The meets at which teams compete support both tournaments and skill-set based challenges. Victory at these meets allows winning teams to qualify for the world competition.

To be successful this year the team must produce a functioning robot using only authorized parts in a design that falls within the physical limitations specified for “In the Zone.” In support of this goal, the MAE Senior Design group will design and construct a sturdy mobile robot base upon which is mounted a versatile mechanism used by the robot to interact with the playing field. Complementing this effort, the ECE Senior Design group will address issues of electrical power distribution, motor control, and sensors needed to allow the robot to function on its own in the field of play. ECE Senior Design will also be responsible for programming the robot's micro-controller to support operation under either computer or human control. Once the robot has been built and debugged, team members must learn the operating skills needed to make effective use the robot's capabilities. The goal is to produce an economical robot that can reliably outperform competing designs in a safe and efficient manner.

ECE 486 Project 8: 2018 Unmanned Aerial Vehicle (UAV) for 2018 IARC Competition

Faculty Advisor: Dr. Chung-Hao Chen

Student Group Members: Wayne Conner, Ryan Hull, Bradley McKee, Jan Miketa

Two objectives of this project is to maneuver an Unmanned Aerial Vehicle, or UAV, by using two sensors attached to the device and to establish stabilized flight. These two sensors are designed to detect other objects around it so that it can avoid a collision. They do this by communicating with a computer that is attached to the device. The computer then relays information to a host computer that collects the data during the flight. The Raspberry pi with the Navio 2 shield will serve as platform to control the UAV. From the host computer, the pilot of the device can give the UAV instructions based on information relayed through the sensors.



Figure 1: Unmanned Aerial Vehicle.

The onboard computer is receiving its instructions through a Raspberry transmitter. The transmitter works in junction with a PX4Flow v1.3 smart camera. These are the devices that analyze the area surrounding the UAV and sends information back to the host computer. These devices are primarily used so that the pilot can see and instruct the UAV on its flight path.

The sensors are responsible for detecting hazards, such as walls, ceilings, floors, and any other obstructions. These sensors also are to send the host computer data concerning the stabilization of the drone. Stabilizing the UAV helps the pilot control the direction that the UAV flies. These sensors are to send information to the host computer and the onboard computer so that both receive information concerning the flight.

ECE 486 Project 9: Self Stabilizing Autonomous Boat

Faculty Advisor: Dr. Chung-Hao Chen and Dr. Gene Hou

Student Group Members: Cody Blair, Fredrick T. O'Brien, John Riesbeck, Preston T. Porter



Autonomous Surface Vehicle: Blue Fin

The objective of this project is to measure the rolling of an autonomous surface vehicle (ASV) and to use the measurements for self-stabilization. This method will help guarantee safe traversing across unstable waters for autonomous boats. The ASV, named the *Blue Fin*, promotes merchant work that would rely on autonomous cargo boats. The *Blue Fin* is modeled after a common cargo boat where it will approach docks, using image recognition, load and unload cargo by a mobile hand-crane. The listing and roll associated with marine travel has had a negative effect on past teams attempts to safely autonomously load and navigate the natural waterways required for an ASV. Our intention is to design and build a cost effective reliable solution for these problems, and anticipate it will not only allow for safe navigation but that the improved stability will also improve the handling and control of the navigation systems.

We have divided the stability control into two main problems; how to accurately and quickly measure the roll, and how to minimize or eliminate the measured roll. There are several approaches that have been proposed to obtain data from the rolling of the *Blue Fin*. Each idea boils down to successfully measuring the angle of the boat in reference to the tangent of the earth (level). The angle measurement would be uploaded to an arduino that will control the anti-roll system. Initial ideas for angular measurements are MEMS (Microelectromechanical Systems) and include;

1. An accelerometer that would measure the rate of change from horizontal.
2. A gyroscope which would give us the Yaw, Pitch, and roll.
3. A potentiometer system which would directly measure the angle.

To decide on the idea to implement we considered factors like response time, accuracy, and costs to determine the best option.

To improve the stabilization of the boat, we are currently reviewing 3 counterbalance options;

1. A cable or screw driven counter weight that will traverse the width of the boat as needed to oppose the force of the roll;
2. Water bladders on either side of the boat that are filled or emptied with a small pump as needed.
3. A large articulating Gyro that would apply torque equal but opposite to the roll.

All of these have their pro's and con's, and the best choice has not yet been determined.

ECE 486 Project 10: Hardware-Software Environment for Facial Expression Related Studies of Children with Autism Spectrum Disorder (ASD)

Faculty Advisor: Dr. Khan Iftakharuddin

Student Group Members: Megan Witherow , Saleh Alnafisah, and Fisal Ahmed

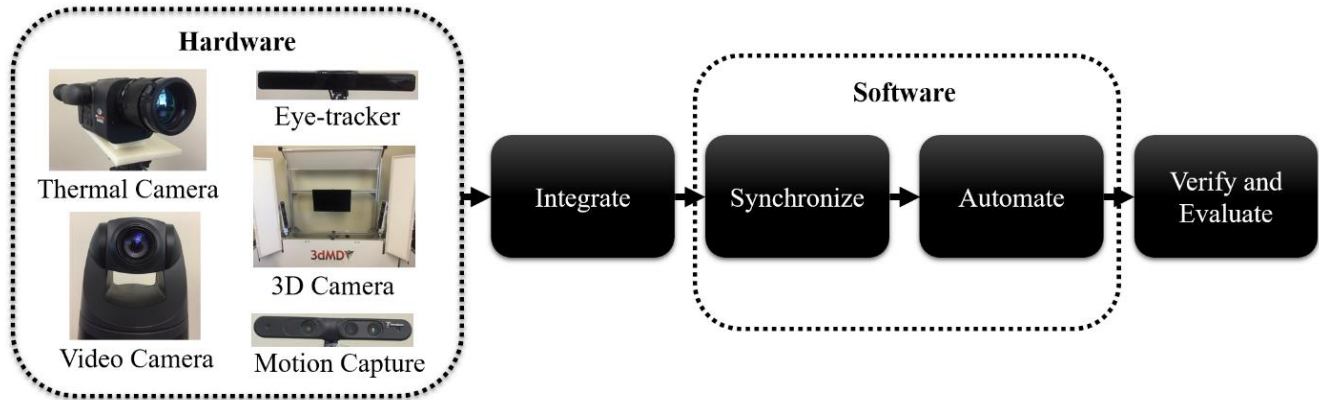

Fig. 1. Pipeline for development of the hardware-software environment.

The goal of this project is to develop a fully integrated, synchronized, and automated hardware-software environment for facial expression related studies of children with Autism Spectrum Disorder (ASD). The new hardware-software platform is a second-generation system that improves upon a previous hardware-software platform created by the ODU Vision Lab for studying the spontaneous facial responses of children with ASD. The new design is intended to improve upon the first hardware-software platform by integrating more sophisticated sensors and improving synchronization and automation procedures. The new hardware-software framework is planned for use in a new pilot study involving subjects with autism. The planned study is expected to facilitate research in this domain and collect detailed subject information that may support development of new interventions for helping children with ASD to improve communication skills in the future. Computer engineering and electrical engineering students are working together on this multidisciplinary project.

The project seeks to integrate a variety of sensors, including 3D stereo camera, thermal camera, eye-tracker, motion capture sensor, and video camera. Each of the sensors accomplishes a specific task in the hardware-software platform. The 3D camera captures multiple stereo images of the subject's face and renders them as a 3D representation of the subject's facial geometry. The 3D images of the subject's face are captured in sequences at ten frames per second, allowing changes in expression to be monitored over time. The thermal camera records the heat energy emitted by the subject, which is intended for monitoring stress levels. The eye tracker captures the subject's eye movement and records information on the visual interest of the subject. The motion capture sensor records the subject's facial expressions as activations of certain regions on the face, which can then be correlated with specific facial muscles. The video camera captures 2D color video of the subject's movement and facial expressions.

The pipeline for the project is shown in Fig. 1. Testing of the individual sensors and integration into the overall system is the first step of the project. Appropriate selection and placement of the sensors is essential for collecting useful data. The synchronization and automation steps to follow require a software design capable of managing all of the sensors. The integration, synchronization, and automation of the various sensors will be followed by verification and evaluation of the framework. In the evaluation step, synchronous collection of data will be performed by capturing data from a sample consisting of members of the Vision Lab.

ECE 486 Project 11: Transient Plasma Ignition

Faculty Advisor: Dr. Jiang

Student Group Members: Christopher Tremble, David Alderman

The purpose of this project is to design a chamber to allow for a controlled combustion of a methane and dry air mixture through the use of a transient plasma ignition source. The chamber will be sealed airtight and must also be able to withstand the pressures of combustion and the likely increases in pressure when the transient plasma quickens the ignition over the standard thermal spark. The increase in speed of ignition translates into a more efficient reaction and thus can lead to less fuel use and fewer polluting particulates left over after igniting.

As the chambers design stands, currently connected is the fuel/evac valve for fueling the chamber and clearing after a reaction, the spark plug to ignite the fuel, and a transducer to measure pressure changes. Due to the fact that the design is modular, it can allow for a window to be attached so the combustion can be observed via an ICCD camera to compare reaction speed and shape between transient plasma frequencies.

Along with the chamber design our group is also designing several different spark plugs for inducing the transient plasma field. The ideal outcome is to create a field which ignites the fuel air mixture throughout the chamber all at once rather than having the reaction center around the spark plug. A thorough and instantaneous reaction means a more efficient combustion where already combusted fuel doesn't hamper the unignited fuels reactions.

In the future a laser input window as well as the beam dump counterpart can be attached additionally to help measure the presence of certain pollutants.

